



Etrema Products, Inc.

ULTRASONIC TRANSDUCER

CU18A

WWW.ETREMA.COM (800) 327-7291
(515) 296-8030

FEATURES

- **HIGH DYNAMIC FORCE – 3250 N**
- **LOW VOLTAGE DRIVE – 0-100 V**
- **15 KHZ TO 20 KHZ HORN BANDWIDTH**
- **CONTINUOUS OR PULSE MODE**
- **OPERATES FROM DC TO 20 KHZ**
- **ACTIVE COOLING**
- **THERMAL PROTECTION**
- **OVER-CURRENT PROTECTION**
- **IMMERSION CAPABLE**
- **MAGNETICALLY BIASED**
- **NO MAGNETIC FLUX LEAKAGE**
- **SIDE MOUNTING FEATURE**

APPLICATIONS

- **ULTRASONIC SOURCE**
- **MICROPOSITIONING**
- **SONOCHEMISTRY**
- **ULTRASONIC BATH**

GENERAL DESCRIPTION

The CU18A is a magnetostrictive transducer that can supply vibrations up to 20 kHz. An internal thermal monitor protects the drive coil from overheating by limiting the current driven into the transducer. The transducer can be driven by any low impedance power amplifier including linear and switching power amplifier topologies.

The CU18A is a single phase electrical device that can accept electrical current from DC to 20 kHz and produces displacement from DC to 20 kHz. The displacement can be used for a variety of applications including micro positioning, ultrasonic driver for sonotrodes, and source for ultrasonic baths.

The CU18A will produce motion proportional to the input current waveform within the limits imposed by the dynamics of the load and impedance of the transducer. This capability provides a convenient method for users to produce a wide range of motion profiles simply by producing the commensurate waveform in current.



CU18A ABSOLUTE MAXIMUM RATINGS

PARAMETER	VALUE	UNITS
Supply Voltage	250	V
Supply Current	10	A
Temperature, Storage	150	C
Operating Temperature Range	0 to 100	C
Side Load [†]	9.0	N m
Axial load – CU18A in compression	8500	N
Axial load – CU18A in tension	3250	N
Output coupling torque	16.9	N m

Stresses beyond those listed under "Absolute Maximum Ratings" may cause permanent damage to the device. These are stress ratings only and functional operation of the device at these or any other conditions beyond those indicated in the operational sections of the specifications are not implied. Exposure to absolute maximum rating conditions for extended periods of time may affect device reliability.

SPECIFICATIONS

PARAMETER	TEST CONDITIONS	MIN	TYP	MAX	UNITS
Step Output Displacement	$I_{in} = 8$ A Load = 0 g to 38 g	5.5	6	7	μm
Resonant Output Displacement			10		
Input Resistance	DC, T = 25 °C	0.5	1	2	Ω
Cooling	4.1e5 Pa (60 psi) Quick disconnect for inlet, exhaust muffler for outlet		8.5e-4 (1.5)		kg s^{-1} (scfm [‡])
Coupling Coefficient, k_{eff}			22.2		%
Relative Permeability			3.4		
Transduction coefficient			90		N/A
Elastic Modulus			38.1		GPa
Dynamic Mass	External load = 0 g		15.1		g
Total Transducer Mass			825		g

TYPICAL PERFORMANCE CHARACTERISTICS

The typical performance characteristics shown were produced with the CU18A mounted and cooled using 1.5 scfm airflow with an exhaust diffuser. All swept-sine plots were generated using a voltage-controlled power amplifier while the input signal was swept from 5 kHz to 30 kHz. The displacement of the output boss or horn was measured using a MTI photonic sensor, model MTI-2000 (Probe module 2032R). The drive voltage (0 to peak) and current were measured using an Instruments Inc model VIT-13.

For the step input plots, a voltage step was input across the leads of the CU18A while the resulting motion was measured using a MTI photonic sensor, model MTI-2000 (Probe module 2032R). The current was measured using a Fluke model 80i-100s current probe.

Two masses were attached to the output boss of the CU18A during generation of the different load plots.

All data was collected using a 50 kHz spectrum analyzer, Siglab model 50-21.

[†] Side Load is defined as the mechanical moment that the output boss must resist due to a transverse load applied at a distance.

[‡] scfm is defined at 1 atmosphere and 70 °F (21 °C)

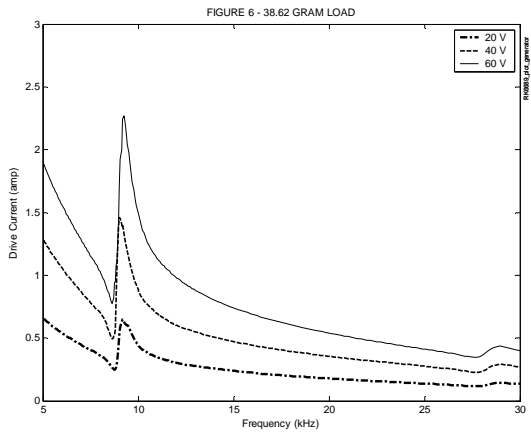
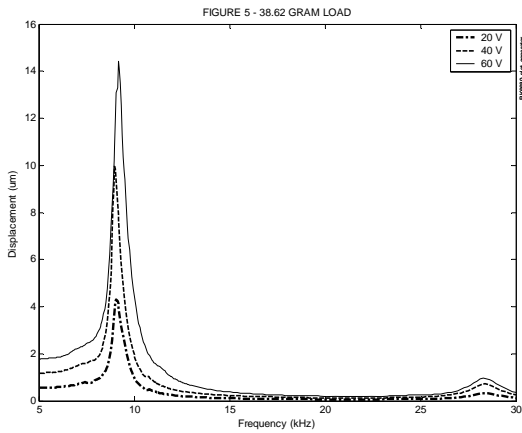
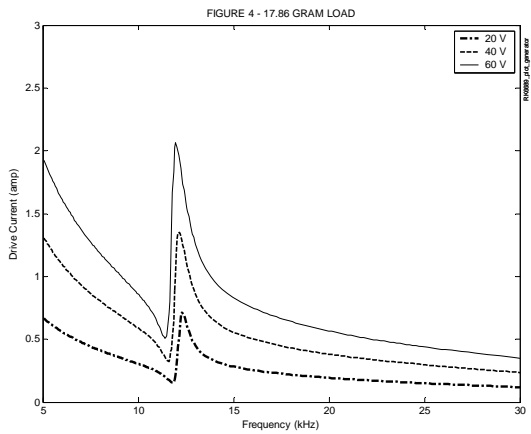
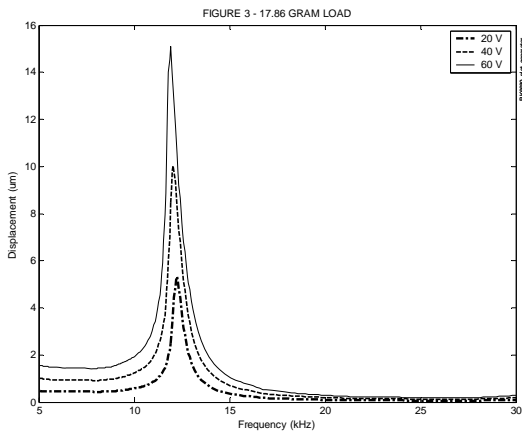
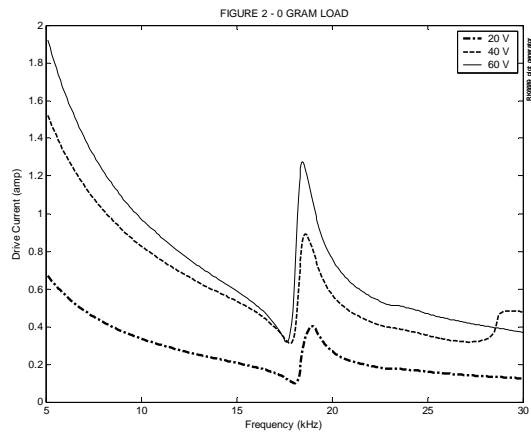
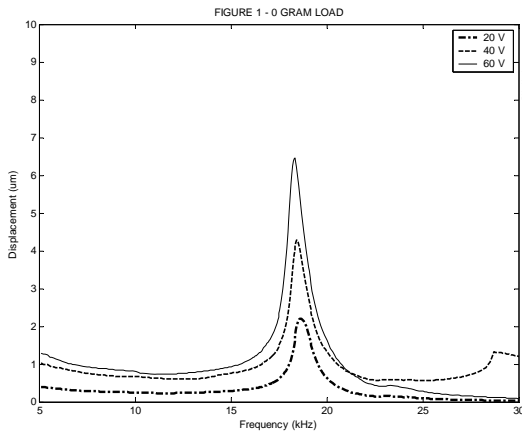

Figures 1, 3 and 5 show transducer output displacement responses as a function of frequency, drive voltage, amplitude and mass load. Figure 1 shows a resonant response around 18 kHz at all drive amplitudes when no external load is attached. Careful examination of the responses shows that resonant frequency of the device is slightly lower at the 60 V drive level than the 20 V case. Figures 3 & 5 show how increasing driven mass lowers the system’s resonant frequency at all drive levels.

Figures 2, 4 and 6 show transducer current draw as a function of frequency, drive voltage amplitude and mass load.

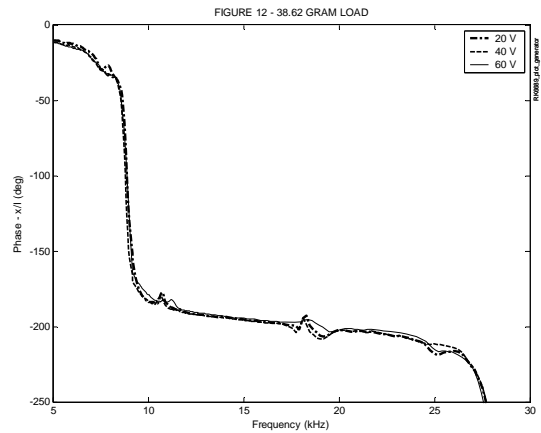
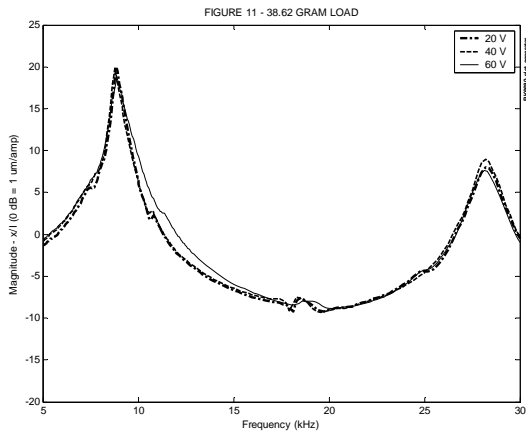
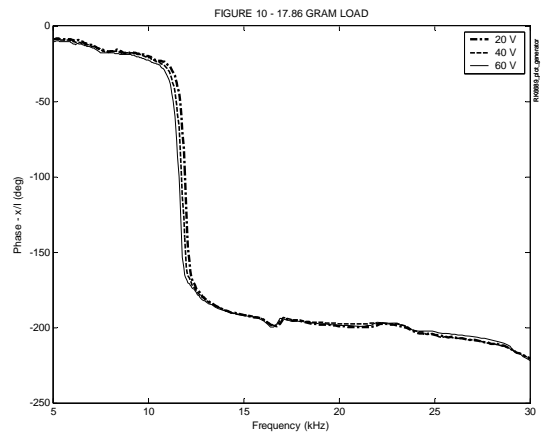
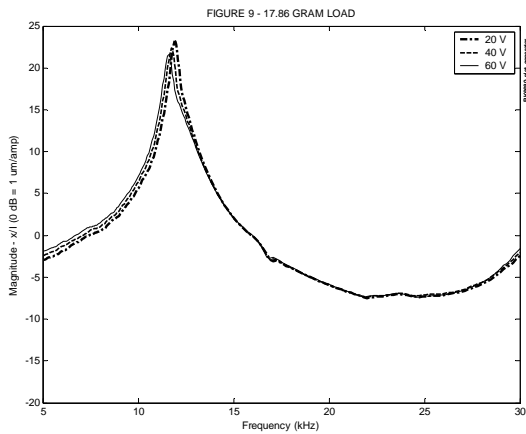
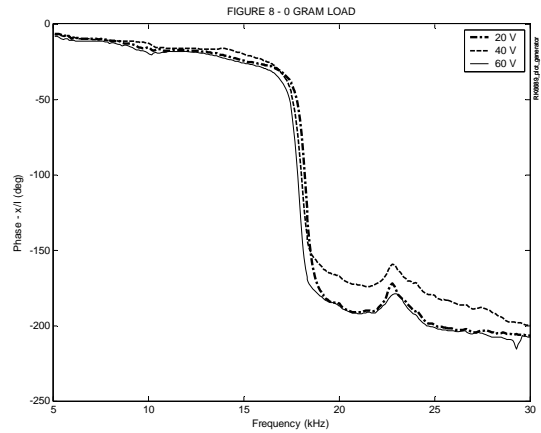
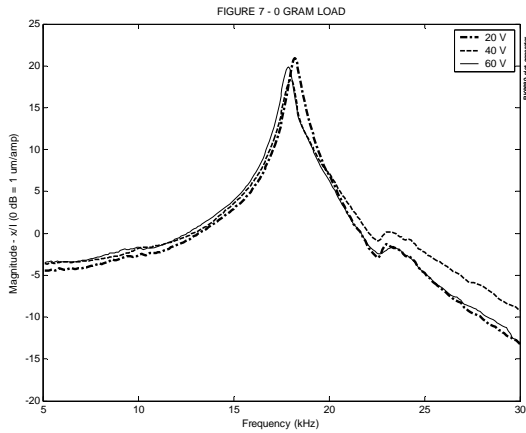

Figures 7, 9 and 11 show the magnitude of the current to displacement frequency response function as a function of drive voltage amplitude and mass load.

Figures 8, 10 and 12 show the phase of the current to displacement frequency response function as a function of drive voltage amplitude and mass load.

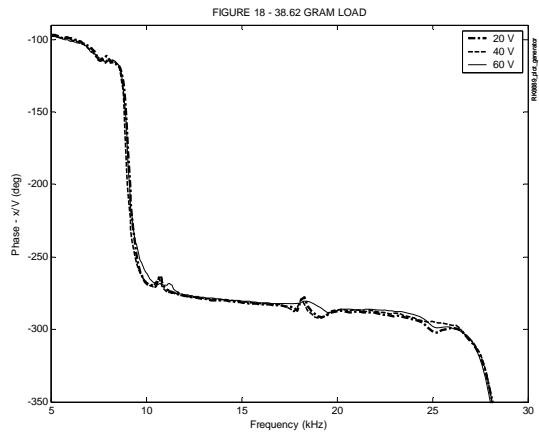
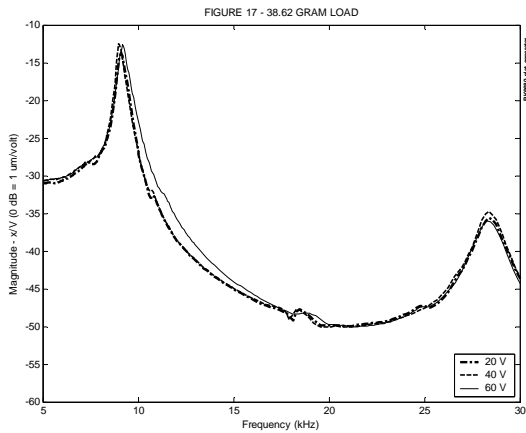
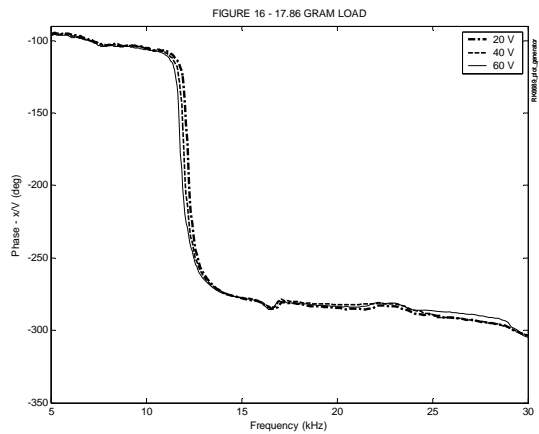
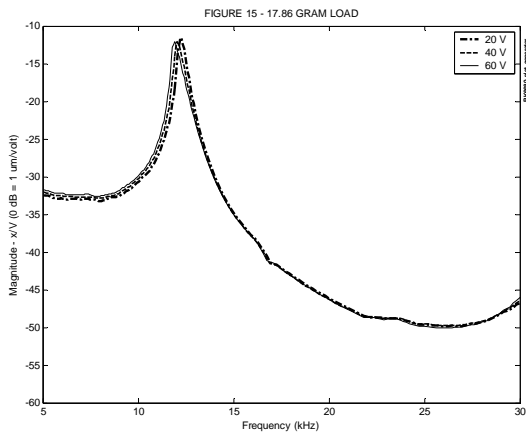
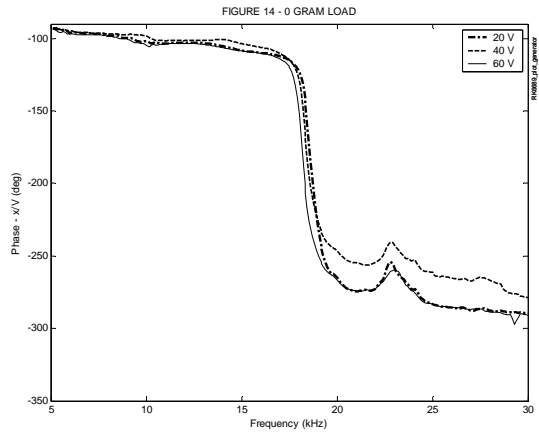
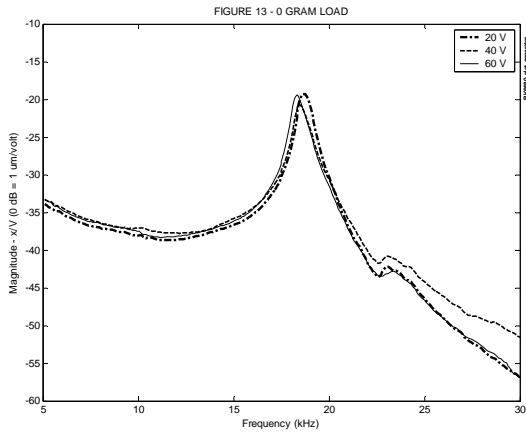

Figures 13, 15 and 17 show the magnitude of the voltage to displacement frequency response function as a function of drive voltage amplitude and mass load.

Figures 14, 16 and 18 show the phase of the voltage to displacement frequency response function as a function of drive voltage amplitude and mass load.

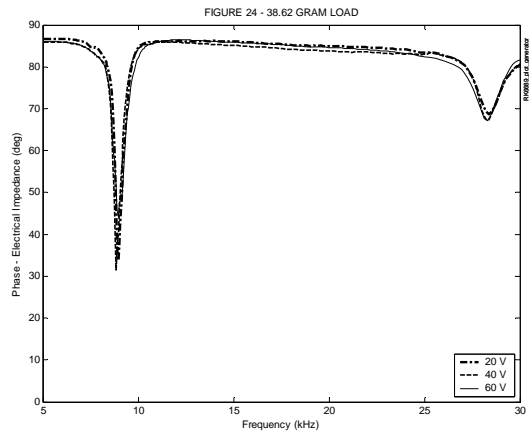
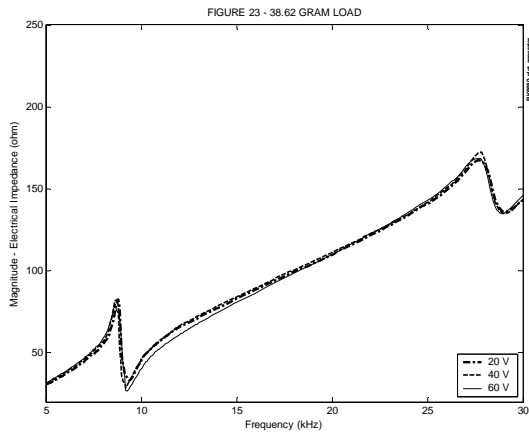
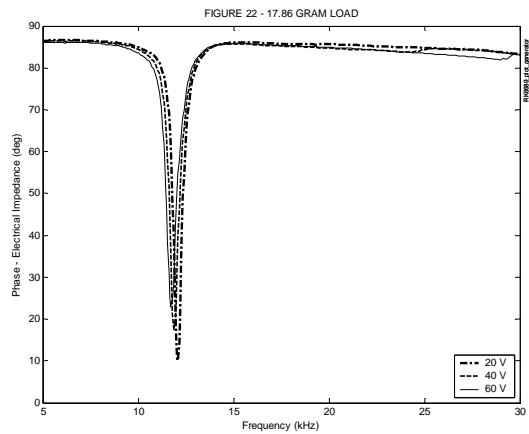
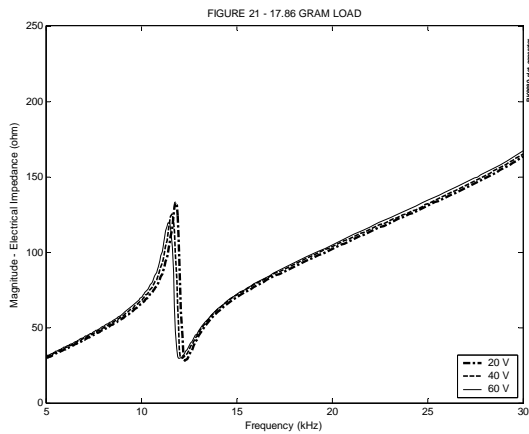
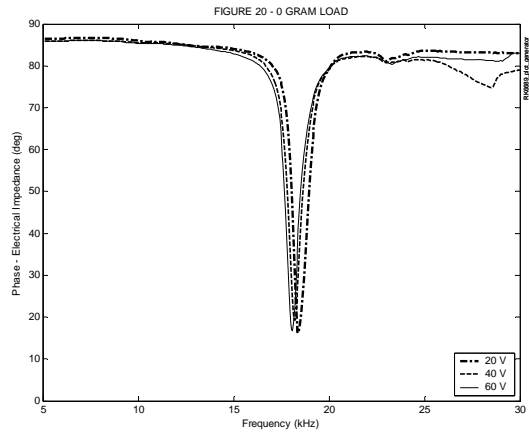
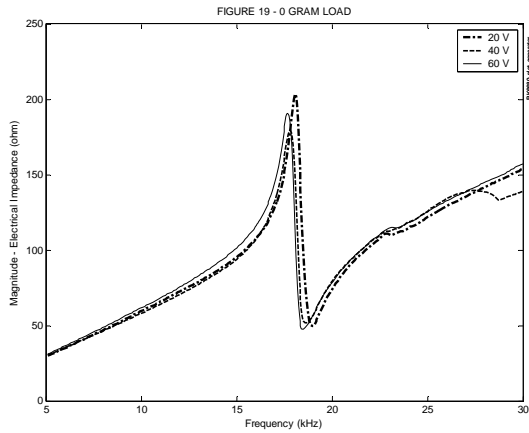

Figures 19, 21 and 23 show the magnitude of the electrical impedance response function as a function of drive voltage amplitude and mass load.

Figures 20, 22 and 24 show the phase of the electrical impedance response function as a function of drive voltage amplitude and mass load.

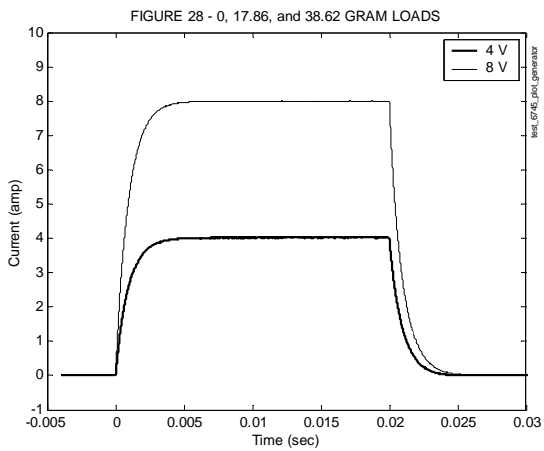
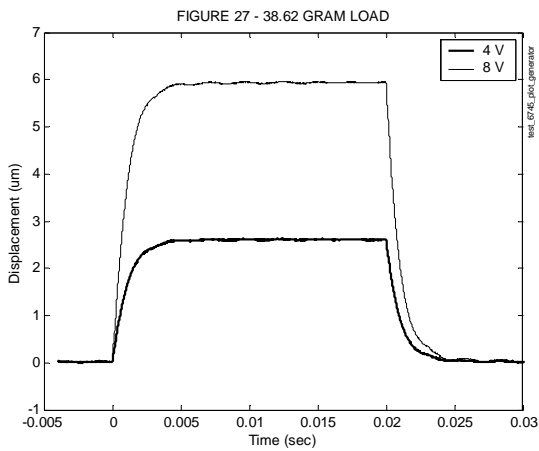
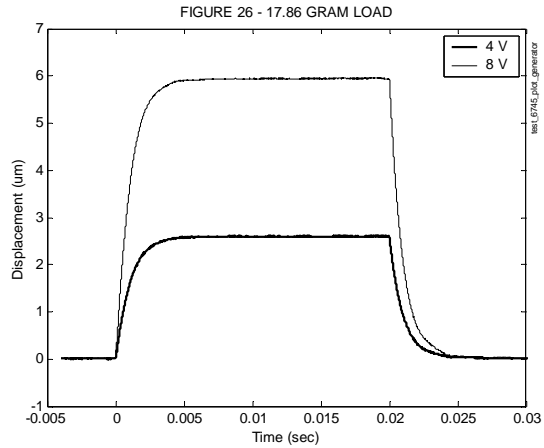
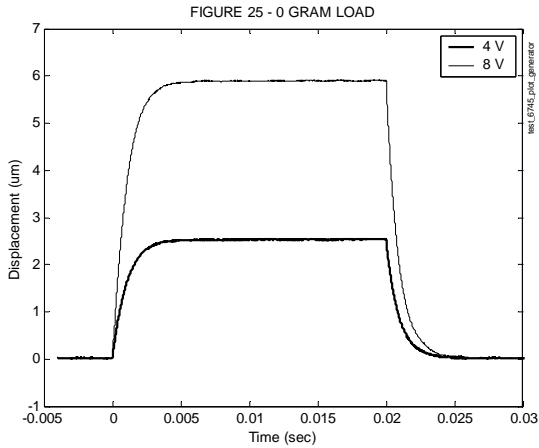

Figures 25-27 show the transient displacement response of the transducer when a voltage step input is applied. Mass loading does not appear to have a large impact on response, though minor displacement ringing can be detected in the 38 gram data.

Figure 28 shows the transient current draw of the transducer when a voltage step input is applied. Mass loading does not appear to have a large impact on response.

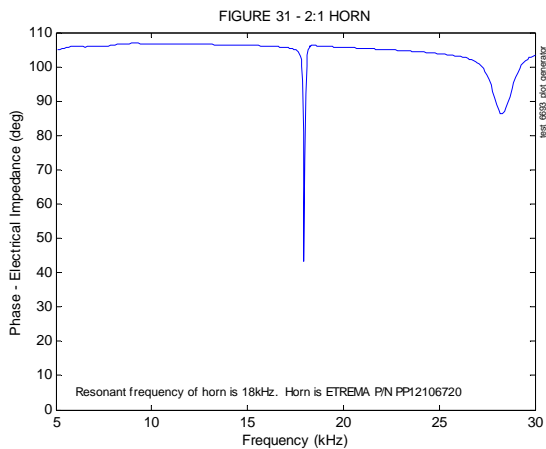
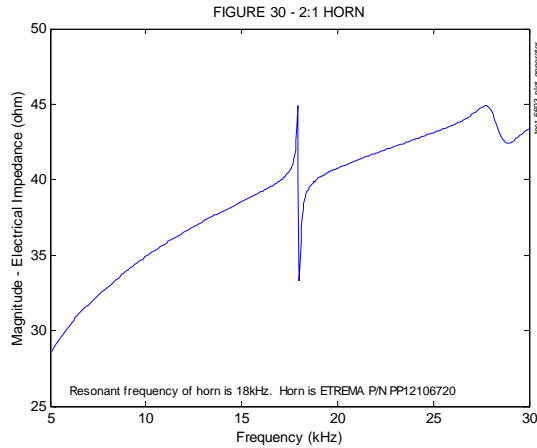
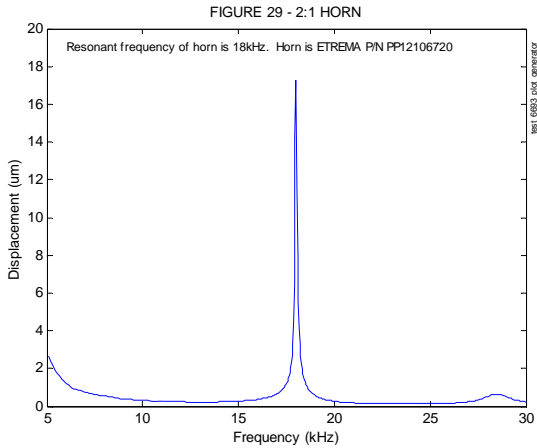

Figure 29 shows the horn tip displacement response as a function of frequency at 100 V 0-peak voltage amplitude while the horn operates in air. The mechanical quality factor (Q) of the system is much greater than for an unloaded transducer. Testing indicates that the resonance of the system is dominated by the horn resonance (i.e. a 16 kHz horn would cause the system to resonate very near 16 kHz). A precise frequency control is needed to obtain maximum performance from this horn.

Figure 30 shows the magnitude of the transducer electrical impedance with a horn attached. Drive voltage amplitude is 100 V 0-peak.

Figure 31 shows the phase of the electrical impedance phase angle with a horn attached. Drive voltage amplitude is 100 V 0-peak.

MECHANICAL DIMENSIONS

Mounting holes are provided on the side of the CU18A transducer. See Figure 32 and Figure 34 for interface dimensions.

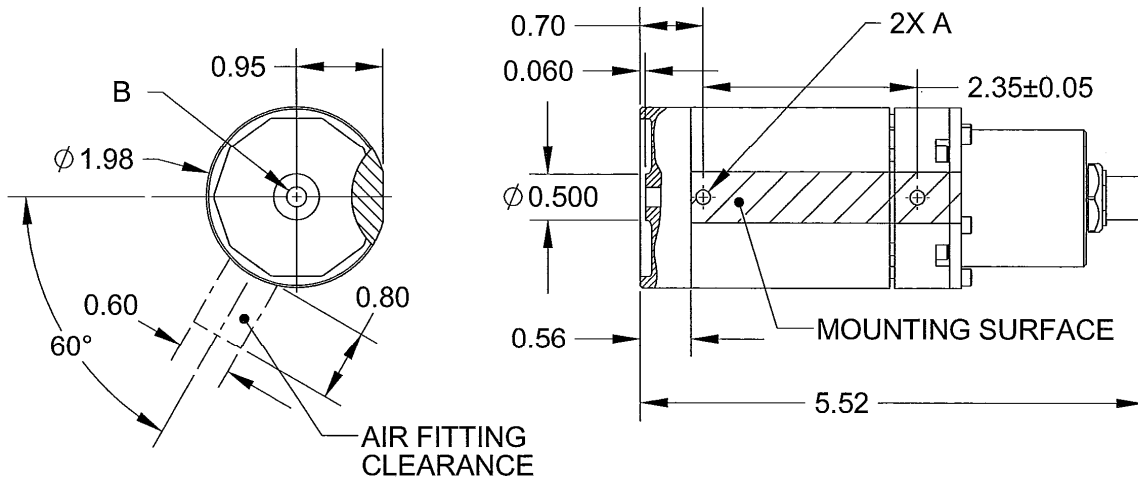

THREADED FEATURE	ENGLISH PP12107250	METRIC PP12107255
MOUNTING HOLES (A)	10-32 ∇ 0.38	M5x0.8 ∇ 10.0mm
OUTPUT BOSS (B)	1/4-28 ∇ 0.45	M6x1.0 ∇ 11.4mm
AIR FITTINGS	10-32	M5x0.8

Figure 32: Physical dimensions. All dimensions are in inches unless otherwise indicated.

The output of the transducer is a female threaded connector with elevated shoulder (output boss); see Figure 32. Interfacing components to the CU18A must have a 1/4-28 male thread (PP12107250 versions) or a M6x1.0 male thread (PP12107255 versions) with a flat mating surface to shoulder against the output boss.



Figure 33 Reverse view of CU18A. Flat surface for mounting extends to front cap.

RECOMMENDED INTERFACE DIMENSIONS

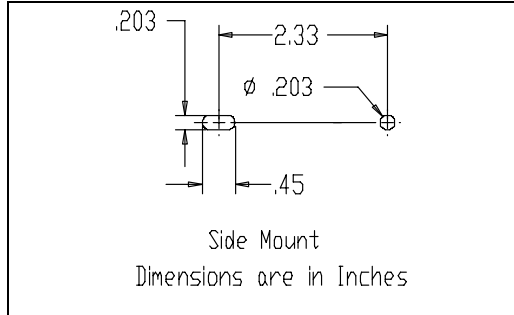

Figure 34: Physical dimensions for the mount interface.

The recommended interface bolt pattern is shown in Figure 34. The interface in the CU18A is 10-32 (PP12107250 versions) or M5x0.8 (PP12107255 versions) threaded holes as shown in Figure 32.

RECOMMENDED TORQUE

The recommended torque to pre-load the threads sufficiently to provide good coupling and eliminate thread backlash between the load and CU18A output boss is 13.6 N m. Exceeding 16.9 N m of torque may cause damage to the device.

ELECTRICAL CONNECTIONS

The electrical connector is a M12 industrial connector. The definitions for the pins are found in Figure 35 and Table 1. Mating cables can be ordered from Etrema. See Table 8.

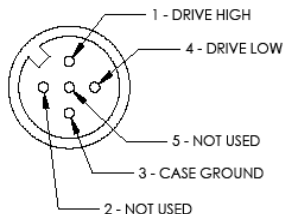

Figure 35: Pin out of M12 electrical connector.

Table 1: Electrical connector function and wire color cross reference.

Pin Number	Wire Color	Function
1	Brown	Drive high
2	White	Not used
3	Blue	Case ground
4	Black	Drive low
5	Grey	Not used

The CU18A is a magnetostrictive, magnetically biased transducer. Electrically, the transducer can be considered to be a resistor and inductor in series as shown in Figure 36.

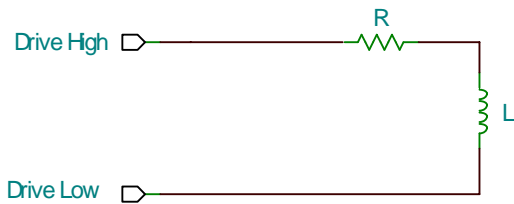

Figure 36: Simplified equivalent circuit of CU18A electrical circuit.

THEORY OF OPERATION

Magnetostrictive actuators convert magnetic energy into mechanical motion. In the CU18A, a time-varying magnetic field is generated proportional to the current flowing through the drive coil. The magnetostrictive material responds by inducing strain within the material. This strain is coupled to the output boss of the actuator.

As the output boss moves in response to the induced strain, the load attached to the boss moves also. Due to the magnitude and frequency of the motion, the load must be securely coupled to the output boss. Any load threaded to the output boss must be shouldered against the boss to remove backlash in the threaded connection between the boss and load.

OPERATING CONSIDERATIONS

GENERAL

The CU18A is designed to operate from 10 kHz to 20 kHz with a single axial resonance near 18 kHz. Additional resonant frequencies are present below 10 kHz. However, this does not preclude the operation down to low frequencies, including DC. The user must evaluate the needs of the application versus the performance of the CU18A to ensure that the device is capable of meeting the requirements demanded by the user's particular application.

DYNAMIC FORCE CALCULATIONS

The CU18A is capable of producing up to 3250 N of dynamic force. To calculate the dynamic force required to drive a non-resonant mass[§], use the following formulae:

$$F = ma \quad (1)$$

$$a = \omega^2 x \quad (2)$$

$$\omega = 2\pi f \quad (3)$$

[§] These equations do not apply to structures at a resonant frequency (such as an ultrasonic horn tuned to 18 kHz being driven at 18 kHz).

where F is dynamic force (N), m is dynamic mass** (kg), a is acceleration ($m\ s^{-2}$), ω is circular frequency (rad/s) and x is displacement (m, 0-pk), and f is angular frequency (Hz)

Example

A 20g external mass is driven at a frequency of 12.0 kHz and a distance of 20 μ m peak-to-peak. Calculate the dynamic force required from the transducer.

$$m = 20\ g + 15.1\ g^{\S} = 0.0351\ kg$$

$$\omega = 2\pi \cdot 12000 = 75400\ \frac{rad}{s} \quad (3)$$

$$x = 10\ \mu m \quad (0 - pk)$$

$$a = \left(75400\ \frac{rad}{s}\right)^2 \cdot (10 \cdot 10^{-6}\ m) = 56850\ \frac{m}{s^2} \quad (2)$$

$$F = (0.0351\ kg) \left(56850\ \frac{m}{s^2}\right) = 1995\ N \quad (1)$$

$$F=1995\ N$$

OVERCURRENT PROTECTION

The CU18A is equipped with an over-current protection circuit that prevents damage to the device due to excessive current flow. Operation above the maximum drive level for a particular ambient temperature will activate the protection circuit. This will result in an open circuit. To reset the protection circuit, remove drive voltage and wait two minutes. The device will automatically reset and be ready for further operation.

At ambient temperatures above 25 C the protection circuit may trigger at or below the maximum rated current input. Consult the cooling requirements section for further details on ambient temperature effects on CU18A operation.

COOLING REQUIREMENTS

The CU18A may be actively cooled by supplying compressed air to the transducer. This extends the duty cycle for the transducer as shown in Table 2 and Table 3. The cooling air should be oil-free and dry. A standard 5 micron compressed air filter should be used upstream of the CU18A to filter oil and particulates from the air.

** The dynamic driven mass of the base transducer (without external load attached) is 15.1 g.

The pressure required to supply the specified flow rate of cooling air is highly dependent on the air fittings used. The exhaust muffler requires 55-60 psi of pressure, while the quick disconnect fitting only requires about 10 psi to supply the same cooling air flow rate.

Table 2: Maximum time at operating condition with no cooling.

No Cooling Drive Level	Ambient Temperature		
	25 C	60 C	80 C
20V	Continuous	Continuous	Continuous
50V	Continuous	350 sec	300 sec
100V	60 sec	45 sec	30 sec

Table 3: Maximum time at operating condition with cooling.

1.5 SCFM Air Drive Level	Ambient Temperature		
	25 C	60 C	80 C
20V	Continuous	Continuous	Continuous
50V	Continuous	Continuous	Continuous
100V	Continuous	90 sec	45 sec

(Note: Extrapolating beyond this table is not recommended. Please contact ETREMA Products for recommendations for your specific application.)

POWER AMPLIFIERS

The CU18A may be driven by any power amplifier capable of supplying the necessary voltage and current for the application. In general, the CU18A is an inductive device; therefore diodes should be incorporated in the power supply to protect the power supply from the inductive fly back.

Linear, full and half H-bridge power amplifier topologies are acceptable for use with the CU18A. See Table 9 for recommended power amplifiers.

HOW TO CHOOSE A POWER SUPPLY

Consider an application that requires a CU18A to drive a massless load at 15 kHz and achieve 4 μm of displacement from zero to peak.

Since this is a sinusoidal type of drive condition, consider the swept-sine set of graphs shown in Figure 1.

A review of Figure 1 indicates that at 15 kHz, a 60 V drive amplitude can achieve a 1.0 μm displacement. A check of Figure 2 indicates that approximately 0.6 ampere of current was used

to achieve the displacement at 15 kHz. Finally, a check of Figure 7 indicates that the ratio of displacement to current is approximately 4 dB at 15 kHz.

Convert 4 dB into a gain ratio by inverting Eq 4.

$$4 \text{ dB} = 20 \log \left(\frac{y \frac{\mu\text{m}}{\text{amp}}}{1 \frac{\mu\text{m}}{\text{amp}}} \right) \quad (4)$$

$$y = 10^{\frac{4}{20}} = 1.58 \quad (5)$$

This means that at 15 kHz, the ratio between current input and output displacement is approximately 1.58 μm per ampere.

To achieve 4 μm of displacement, one will need $(4 \mu\text{m}) / (1.58 \mu\text{m per amp}) = 2.53$ amperes of current.

A check of Figure 19, the magnitude of the electrical impedance, shows that at 15 kHz, the impedance is approximately 100 Ω. Therefore, a voltage of $(100 \Omega)(2.53 \text{ amperes}) = 253$ volts. *This voltage exceeds the recommended continuous maximum voltage for a cooled CU18A as per Table 3.* Therefore, two options exist. First, the application could be achieved with a power supply capable of 253 volts and 2.53 amperes at 15 kHz with limited duty cycle.

Volts needed at 15 kHz: 253
Amperes needed at 15 kHz: 2.53

A second option would be to design the mass load such that it is resonant at 15 kHz. This option will be discussed next.

Start by interpolating the displacement between Figures 1 and 3 for the 60 V drive case. The 17.86 gram load achieves resonance at about 12 kHz with a peak displacement of 15 μm at 60 V drive level. The 0 gram load achieves resonance at 18 kHz with a peak displacement of 6 μm for the 60 V case.

Linearly interpolating the amplitudes of displacement between these two cases for 15

kHz gives the amplitude for a 60 V drive level of 10.5 μm.

Since this case is designed to achieve resonance at 15 kHz, either Figure 7 or Figure 9 can be consulted to determine that, at resonance, the displacement per unit ampere is between 20 and 22 dB. Thus, the gain ratio is between 10 and 12.6 μm per ampere.

Since we desire 4 μm of motion at resonance, we can reduce the drive from 60 V. This can be determined by using the more conservative, 10 μm per ampere ratio.

$$\frac{4 \mu m}{10 \mu m/A} = 0.4 A \quad (6)$$

This application would require 0.4 amperes of current at 15 kHz.

Using the electrical impedance graphs to determine the voltage and currents needed at resonance is not recommended due to the sensitivity of the electrical impedance near resonance. It is better to use x/I and x/V to determine the required current and voltage.

Consider Figures 13 and 15. Interpolating for 15 kHz indicates that at resonance, a displacement per drive volt of approximately -17 dB is needed. This is a gain ratio of 0.141 μm per volt. 4 μm / 0.141 μm per volt gives 28.4 volts needed.

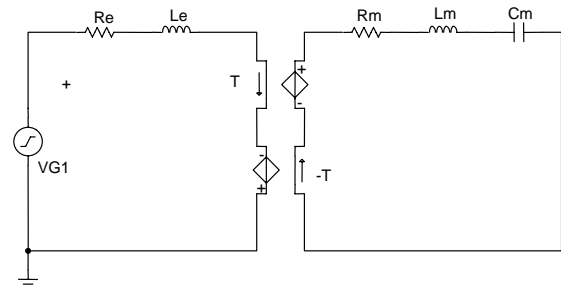

Figure 37: Equivalent circuit of CU18A for SPICE simulation.

```
CU18A Model (PSpice format)
*****
** This file implements the equivalent **
** circuit shown in Figure 37 **
*****
.AC LIN 500 1K 30K
.PROBE V(2,0)
IG1 0 2 DC 0 AC 1 0
+ PULSE (0 1 0 0 0 1e19 1e20 )
VT_in 0 6
HT 0 1 VT_in -89.59
VT_in_2 3 1
HT_2 8 6 VT_in_2 89.59
Le 4 3 854.2U IC=0
Cm 5 0 5.26N IC=0
Lm 7 5 15.1M IC=0
Rm 8 7 60.45
Re 2 4 9.03
.END
```

Figure 38: CU18A SPICE simulation model

EQUIVALENT CIRCUIT MODEL

The CU18A may be modeled as an equivalent electrical circuit as shown in Figure 37, which includes the influence of the mechanical load. The first-order model can be input into any SPICE-type simulation application using the PSpice text file shown in Figure 38 to determine AC and transient responses from different loading conditions. DC analysis is not recommended for this type of equivalent circuit modeling.

Table 4: Equivalent circuit lumped parameters for a CU18A.

Parameter	Variable	Units	Value
Transduction Coefficient	T	N/A	89.59
Damping Coefficient	Rm	N s / m	60.45
Mechanical Compliance	Cm	nm/N	5.26
Dynamic Mass	Lm	g	15.1
DC Resistance	Re	Ω	9.03
Inductance	Le	μH	854.2

This model has the equivalent lumped electrical parameters in the left hand mesh, while the lumped mechanical parameters are located in the right hand mesh. The driving force is the voltage across the electrical mesh. The output velocity of the transducer is simulated as the current flow in the right-hand mesh.

TYPICAL APPLICATIONS

The CU18A is well suited for many different types of applications. Most applications can be considered variations on a theme, in that; a CU18A is actively driven by electrical current to produce output mechanical motion.

Figure 39 through Figure 41 show typical CU18A connections for different types of applications.

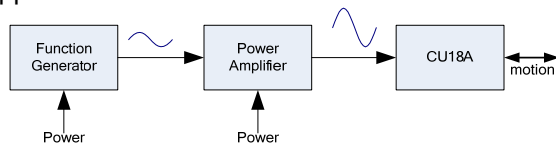

Figure 39: Typical open loop CU18A interconnect sequence.

Figure 39 is representative of most open loop applications. This is typical of applications where the CU18A is used as a vibration source where output amplitude and frequency are not critical to the application.

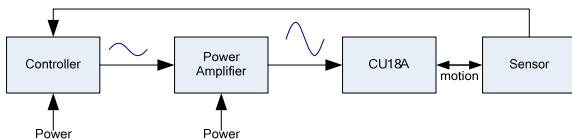

Figure 40: Typical closed loop CU18A interconnect sequence.

Figure 40 is representative of most closed loop applications. This is typical of applications where the CU18A is used as a vibration source where output amplitude and frequency are critical to the application. Examples include active vibration control and controlled vibration sources for fatigue testing.

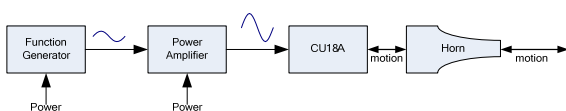

Figure 41: Typical cavitation generator interconnect sequence.

Figure 41 is representative of most cavitation and sonochemistry applications. This is typical of applications where the CU18A is used as a vibration source and the displacement is

mechanically amplified with the mechanical waveguide (i.e. horn).

OBTAINING MAXIMUM DISPLACEMENT

To obtain maximum displacement from the CU18A, the transducer must be operated at the system's resonant frequency. The system's resonant frequency is affected by the type of load being driven, so it is recommended that the transducer's operating drive conditions be established for each new application.

If independent displacement or acceleration equipment is available, this can be used to identify the frequency at which maximum displacement is achieved.

If a tuned horn is used to generate cavitation in a liquid medium, drive the transducer at the frequency which the horn is tuned at (usually 18 kHz). Then, adjust the frequency slowly (1-2 Hz at a time) above and below the starting frequency to find the frequency that produces maximum cavitation.

SUBMERGED OPERATION CAUTION

Operating the CU18A while submerged may lead to cavitation-induced wear of the flexure face. This is normal. In general, the greater the drive level, the faster the erosion occurs. However, excessive run time under these conditions may ultimately lead to failure of the flexure and the loss of seal integrity. Thus, the user is cautioned to evaluate the suitability of the CU18A for the application.

ACCESSORIES AND ORDERING INFORMATION

Table 5: ACTUATOR ORDERING OPTIONS

CU18A Ordering Options	Interface Thread Version	
	English	Metric
Side Mount	PP12107250	PP12107255

Table 6: AIR ACCESSORIES

Air Accessories Part Numbers	Interface Thread Version	
	English	Metric
Quick Disconnect Fitting	VE12106759	VE12106765
Tubing (use with Quick Disconnect Fitting)	VE12106760	VE12106766
Hose Barb	VE12106761	VE12106767
Hose (use with Hose Barb)	VE12106762	VE12106768
Exhaust Diffuser	VE12106763	VE12106763
Seal Plug	VE12106764	VE12106770

Table 7: HORNS AND BOOSTERS

Horns & Accessories Part Numbers	Interface Thread Version	
	English	Metric
2:1 Gain Horn	PP12106720	PP12106728
1.5:1 Booster	PP12106721	PP12106741
5:1 Microtip Horn	PP12106722	PP12106742

Table 8: CABLE ACCESSORIES

Cable Part Numbers	Meets IP68
Item	
2 m length	VE12106756
6 m length	VE12106772

Table 9: POWER AMPLIFIERS

ETREMA Part Number ^{††}	Country of Use	Voltage / Freq	AC / DC Coupled ^{‡‡}
VS12106773-1	USA/Canada	120V/60Hz	AC
VS12106773-2	USA/Canada	120V/60Hz	DC
VS12106773-3	Cont. Europe	220V/50Hz	AC
VS12106773-4	Cont. Europe	220V/50Hz	DC
VS12106773-5	Cont. Europe	240V/50Hz	AC
VS12106773-6	Cont. Europe	240V/50Hz	DC
VS12106773-7	Japan	100V/50-60Hz	AC
VS12106773-8	Japan	100V/50-60Hz	DC
VS12106775-1	USA/Canada	120V/60Hz	AC
VS12106775-2	Cont. Europe	220V/50Hz	AC
VS12106775-3	Cont. Europe	240V/50Hz	AC
VS12106775-4	Japan	100V/50-60Hz	AC

Table 10: FUNCTION GENERATOR AND ACCESSORIES

Item	Configuration	Part Number
Programmable Function Generator	USA/Canada	VS12106774-1
	Cont. Europe	VS12106774-2
	Japan	VS12106774-3
Interconnect Cable	VS12106773-X amplifiers	VE12106776
Interconnect Cable	VS12106775-X amplifiers	VE12106783
XLR to BNC adaptor	VS12106775-X amplifiers	VE12106784

^{††} VS12106773 variants can be configured for controlled voltage or controlled current mode. VS12106775 variants are only available in controlled voltage mode.

^{‡‡} AC coupled amplifiers will not amplify/pass DC power. DC coupled amplifiers will amplify/pass DC power.

REVISION HISTORY

Date	Revision	Description
July 11, 2007	SD12106777	Initial release
August 28, 2009	A	Updated to new flexure configuration. Added clarification regarding pressure drop dependence upon air fitting configuration. Added clarification regarding AC vs. DC power amplifier functionality and controlled voltage vs. controlled current modes of operation. Clarified that drive voltage for transfer functions is 0-peak voltage. Corrected reference to Figure 7 in power supply sizing example and used 60V drive level for non-resonant example. Changed model designation from CU18 to CU18A. Updated part numbers to PP12107250 and PP12107255. Added interface cable and adaptor for function generator when used with VS12106775-X amplifiers. Provided definition for Side Load.

DISCLAIMER

Information contained in this publication regarding device applications and the like is intended through suggestion only and may be superseded by updates. It is your responsibility to ensure that your application meets with the specifications. No representation or warranty is given and no liability is assumed by ETREMA Products Incorporated with respect to the accuracy or use of such information, or infringement of patents or other intellectual property rights arising from such use otherwise. Use of ETREMA's products as critical components in life support systems is not authorized except with express written approval by ETREMA. No licenses are conveyed, implicitly or otherwise, under any intellectual property rights. ETREMA reserves the right at any time without notice to change said transducer and specifications.

© 2009, ETREMA Products Incorporated.